



SABA BATTERY

**SABA BATTERY INDUSTRIAL
GROUP**

Export Department
2020

SABA BATTERY at a GLANCE

PRODUCTION
of different type of
Batteries

LEAD
production

COPPER
production

CONSTRUCTION
of Battery Recycling
Plant



SABA BATTERY

SABA BATTERY
INDUSTRIAL GROUP

CONSTRUCTION
of lead acid car
batteries production
plant

REFRECTORARY
Materials

CONSTRUCTION
of Lithium
Batteries

SABA BATTERY INDUSTRIAL GROUP



- ▶ **Established in 1958**
- ▶ **SABA Battery** with more than half a century of experience is one of the leading battery manufacturing company in I.R.IRAN produce and provide more than half of the yearly car batteries consumption of Iranian market. With production capacity of 8 million battery a year. **SABA Battery's product exported to many countries such as; Afghanistan, Uzbekistan, Tajikistan, Iraq, UAE, Qatar, Turkey, Azerbaijan, Lebanon, Syria, etc.**
- ▶ **SABA Battery** produces batteries and other relevant products in the field of renewable energy by using advanced and world class machineries and technologies, expert and experienced engineers with high quality raw materials.

SABA BATTERY INDUSTRIAL GROUP



- ▶ **SABA Battery's** range of products in battery's section cover all types of MF and LM car batteries with different amperage from 30 Amps to 200 Amps for light and heavy vehicles, variety of rechargeable lithium batteries , various types of accumulators for forklift trucks, various types of industrial batteries and batteries used for different and special application.

SABA BATTERY INDUSTRIAL GROUP



- ▶ **SABA Battery** is capable of Constructing Complete Automotive and Semi Automotive Battery Production Plant, Complete Automotive Lead Acid battery Recycling Plant and complete Lithium production plant with high efficiency and latest technology.

SABA BATTERY INDUSTRIAL GROUP

Battery Product

- ▶ **STARTER**
- ▶ **Industrial**
 - **VRLA**
 - **OPZ**
 - **OPZS**
- ▶ **Saba Smart**
- ▶ **Lithium**

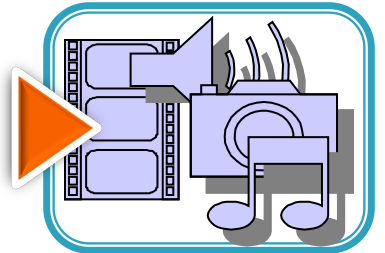
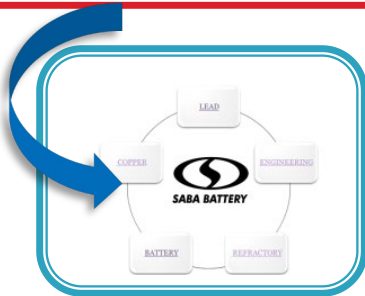

SABA BATTERY INDUSTRIAL GROUP

Starter Batteries

- ▶ **MF & LM BATTERIES**
- ▶ **Production Capacity: 10 Million**
- ▶ **Annual Production: 7 Million**
- ▶ **Wide range of capacity**
- ▶ **Multi Brands (over 60 Brands)**
- ▶ **Competitive Pricing**
- ▶ **Reliable after sales services**



SABA BATTERY INDUSTRIAL GROUP

MF Starter Batteries

- ▶ Start from 30 Amps to 200 Amps
- ▶ European Standard
- ▶ Japanese Standard



SABA BATTERY INDUSTRIAL GROUP

Starter Batteries Range of products

TYPE	CAPACITY (Ah)	CCA (A)		RC(min)	Weight (Kg) (without electrolyte)	Weight (Kg)	Length (mm)	Width (mm)	Height (mm)	Production method
		IEC	EN							
LM (Low Maintenance)	55	320	420	105	10.25	15.1	242	175	190	EXPANDING
	60	380	500	110	10.6	16.9	260	175	227	
	66	450	570	115	12	17.5	276	175	190	
	70	470	540	115	12	17.75	260	175	227	
	74	520	640	120	13	18.2	276	175	190	
	88	540	660	125	13.5	20.200	301	170	225	
	90	620	740	130	15	21.5	380	175	190	
	100	440	500	160	21	30.5	404	175	235	
	120	500	560	170	25	38	510	180	235	
	120	520	580	180	23	33	404	175	235	
	150	580	660	210	30.5	47	540	220	240	
	170	700	740	270	32	48	525	215	240	
	190	720	760	280	33	49	525	215	240	
	200	720	760	280	34	50	525	215	240	
									CASTING	

Voltage 12V

TYPE	CAPACITY (Ah)	CCA (A)		RC(min)	Weight (Kg) (without electrolyte)	Weight (Kg)	Length (mm)	Width (mm)	Height (mm)	Production method
		IEC	EN							
MF (Maintenance Free)	40	210	310	70	7.75	12.2	207	175	190	EXPANDING
	50	290	380	100	8.5	12.4	207	175	190	
	55	320	420	105	10.25	15.1	242	175	190	
	60	380	500	110	11.1	15.5	242	175	190	
	60FX	380	500	110	10.6	16.9	260	175	222	
	66	450	570	115	12	17.5	276	175	190	
	70FX	470	540	115	12	17.4	260	175	222	
	74	520	640	120	12.8	18.2	276	175	190	
	90	620	740	130	14.8	21.5	355	175	190	
	150	900	950	290	29.5	41	525	220	235	
	170	950	1000	320	30	43	525	220	235	

Voltage 12V

SABA BATTERY INDUSTRIAL GROUP

LM Starter Batteries

- ▶ Expand and Punch Technology
- ▶ 55 Amps to 200 Amps



SABA BATTERY INDUSTRIAL GROUP

VRLA Batteries

**Valve Regulated
Lead Acid Battery**

- Long Life
- UPS
- Telecommunication
- 4.5 Amps to 3,000 Amps



SABA BATTERY INDUSTRIAL GROUP

OPZ Batteries

- Sealed
- 110 Amps to 1500 Amps Gel Technology
- Tubular Plates
- IEC60896-21 22



SABA BATTERY INDUSTRIAL GROUP

PZS-OPZS BATTERIES

- ▶ Stationary Batteries
- ▶ High Quality
- ▶ Wide range of Products
- ▶ Easy installation
- ▶ Long life
- ▶ From 2V200ah to 2V3000AH

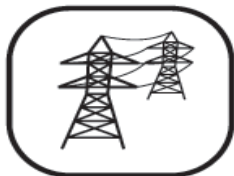

SABA BATTERY
GOHARI INDUSTRIAL GROUP (Sadr Battery)

Stationary Flooded-Tubular Batteries
200 - 3000 Ah OPzS Series

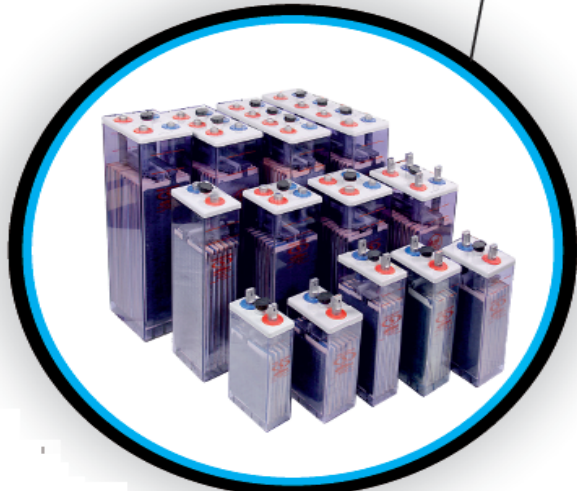

SABA BATTERY INDUSTRIAL GROUP

SABA SMART (Deep Cycle) Series

- ▶ **6V-200Ah**
- ▶ **12V-120Ah**
 - **Tubular Positive Plates , low antimony alloy for decreasing corrosion and elimination of active material effusion.**
 - **Use flooded acid**
 - **Flat negative plates with low antimony alloy**
 - **Low preservation**
 - **Flooded Battery**

UPS INVERTER

Renewable Energy

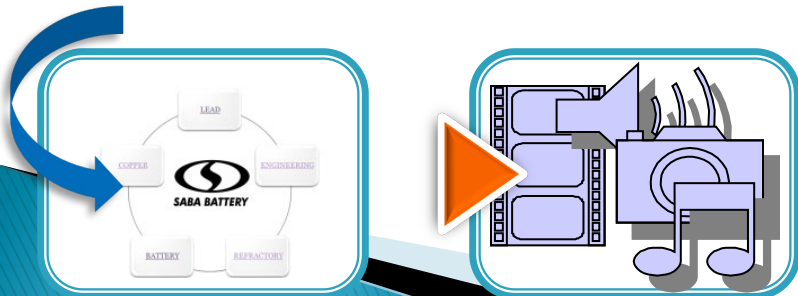

SABA BATTERY INDUSTRIAL GROUP

Lithium Batteries

- Power Banks
- BTS
- Electric Vehicles
- Solar Systems
- Etc.



SABA BATTERY INDUSTRIAL GROUP

Wind Turbine

- **Design and Production of wind turbine power plants from A to Z**
- ▶ **Tower**
- ▶ **Turbine and Generator**
- ▶ **Charge Controller & Inverter**
- ▶ **Lithium Battery pack**



SABA BATTERY INDUSTRIAL GROUP

Combined Heat Plants

- Design and Production of Solar Systems and Hybrid systems from A to Z
- CHP (Portable and fixed)

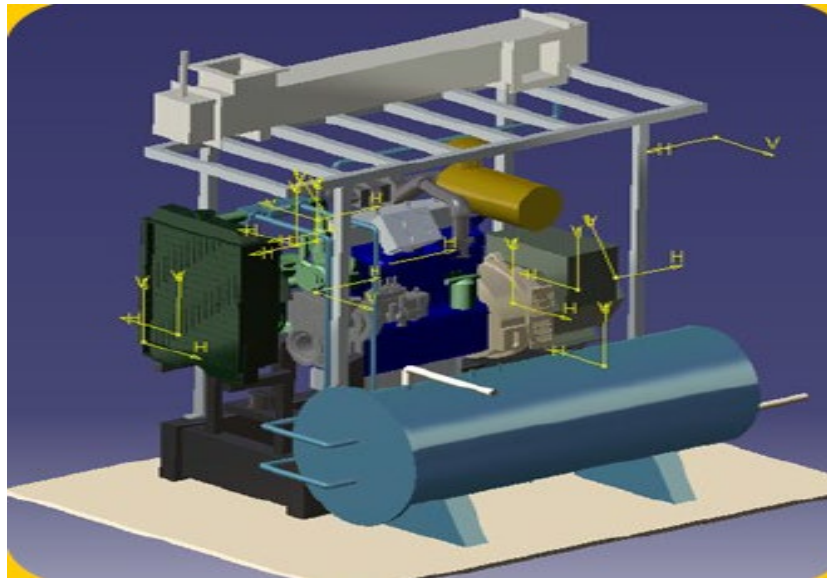
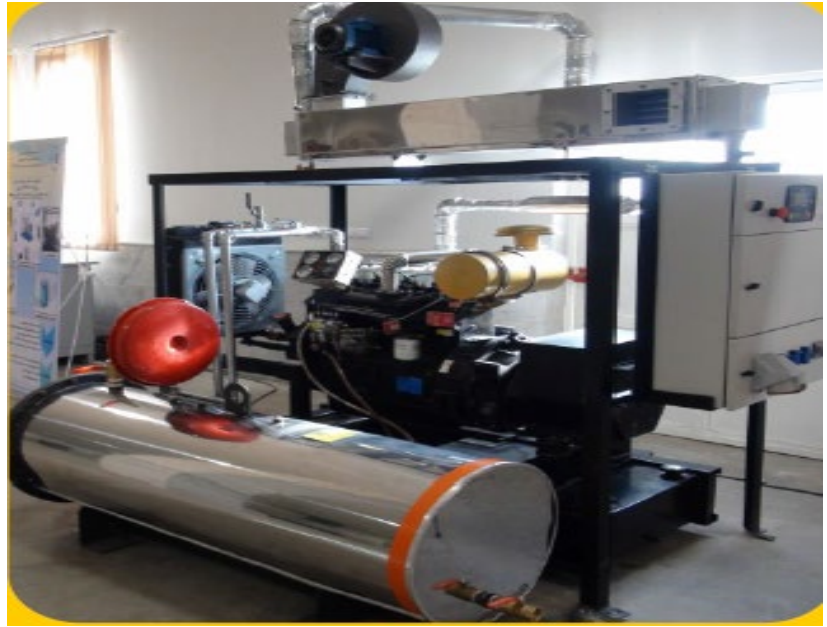

SABA BATTERY INDUSTRIAL GROUP

Water Purifier

- ▶ Solar plates
- ▶ Solar Charge Controller
- ▶ Inverter
- ▶ RO Pack
- ▶ Safety and Security Systems
- ▶ Fixed And Portable



SABA BATTERY INDUSTRIAL GROUP

Gold and Silver Production

► Sub Production of Recycling Factory



SABA BATTERY INDUSTRIAL GROUP

Sodium Sulfate

- ▶ 16 Tons Per Day
- ▶ Increasing Efficiency of Kettles



SABA BATTERY INDUSTRIAL GROUP

LEAD

- ▶ **Type of Technologies**
 - Electrolyte
 - Kettle & Furnace
- ▶ **Lead Production from**
 - Recycling of Scrap batteries
 - Scrap lead
 - Concentrate material

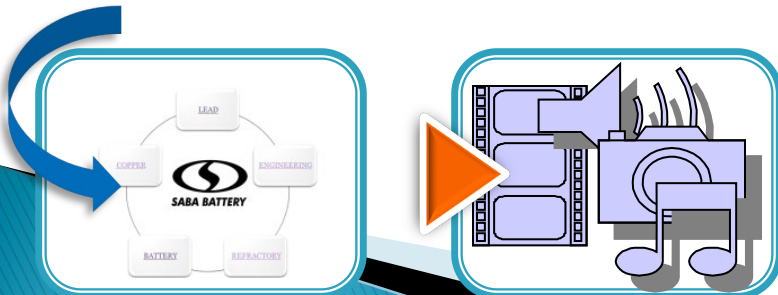
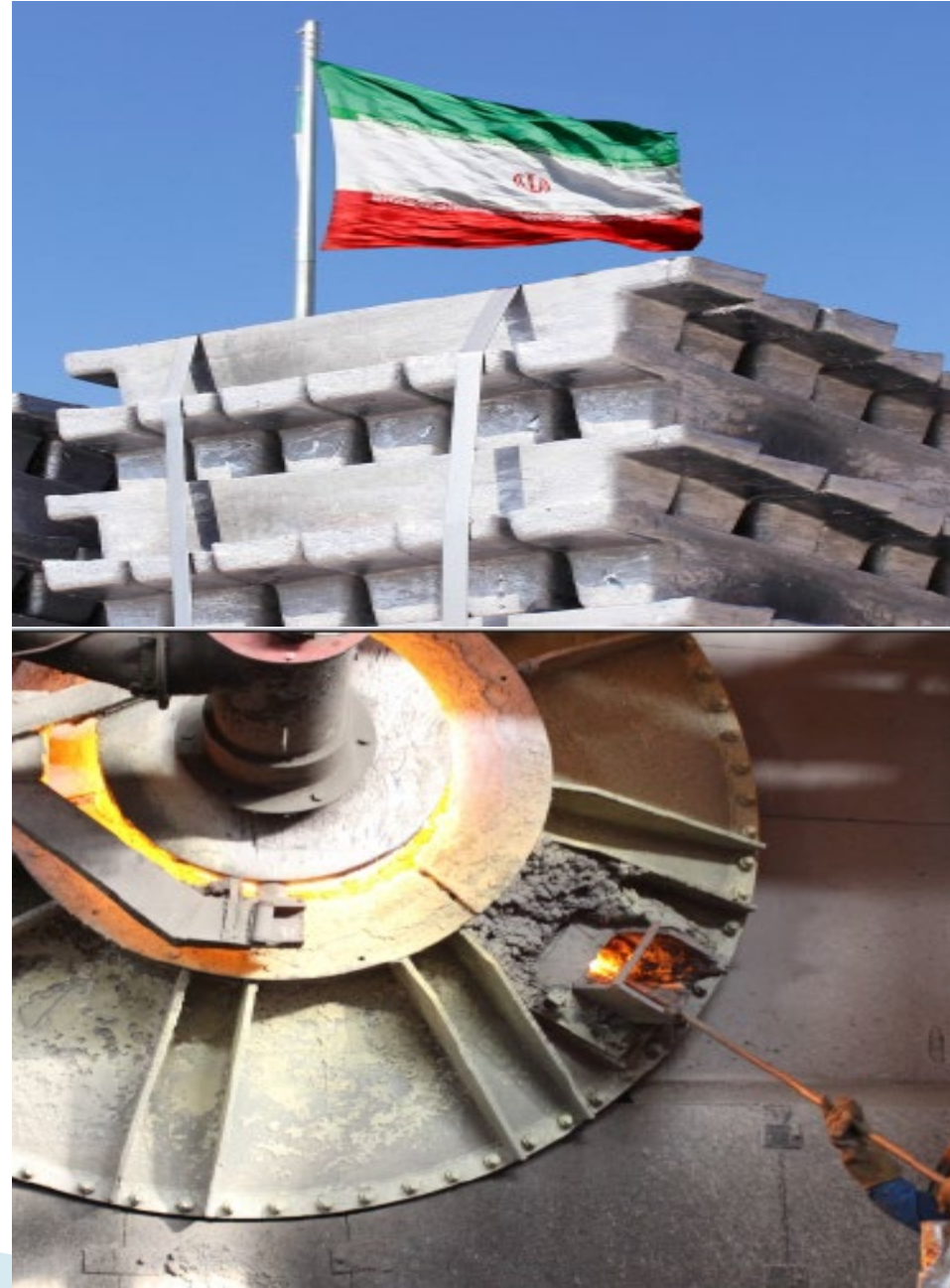

SABA BATTERY INDUSTRIAL GROUP

Lead Products

- ▶ Lead 99.9999
- ▶ Lead Alloys
- ▶ 60,000 Tons Annually

SPL	COS	9.7 AS	LSN	4.5 s
8.7 st	CRN	CRP	5 N	99.99 s
Pb-Ca	L14	RP&RS	Pb-se	L16

Side Products

- PP Chips
 - White
 - Black

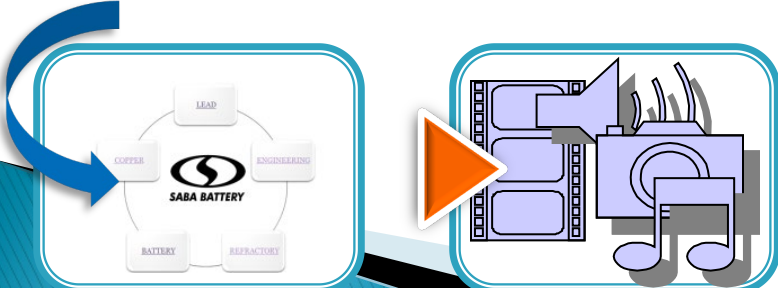

SABA BATTERY INDUSTRIAL GROUP

Copper Cathode

▶ Production from

- Scrap Copper
- Concentrate

Annual Production 6,000 Tons
99.99Purity

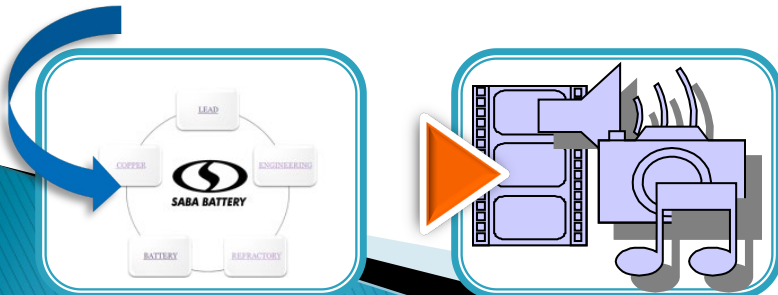

SABA BATTERY INDUSTRIAL GROUP

Antimony

- ▶ 99% Purity
- ▶ To increase Lead stability



SABA BATTERY INDUSTRIAL GROUP

Refractory Products

- **Breaks**
- **Mass**
- **Cements**

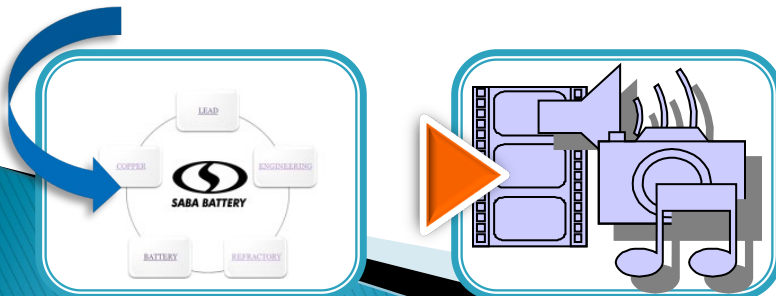

SABA BATTERY INDUSTRIAL GROUP

Engineering and Consultancy

- ▶ Full factory and equipment Supply
- ▶ PLC and Planning
- ▶ Construction and operation
- ▶ Consultancy and planning



SABA BATTERY INDUSTRIAL GROUP

Contact Person

Ali Hosseini

Business Development Manager

Saba Battery Industrial Group (SBIG)

E-mail Address:hosseini.sababattery@gmail.com

Mobile IR:+98 912 530 0183

Whats App:+98 912 530 0183

Tel:+98 21 22567903

Fax:+98 21 22585336

P.o.Box:19575-361



**Thanks For your kind
Attention**

WELCOME

